

PAKGRAPPLE



The **PAKGRAPPLE** is new technology that offers a unique solution to situations that require the versatility of a single machine needing to employ a bucket for excavation and tree removal as well as having a heavy duty grapple with saw available for tree and stump handling. The **PAKGRAPPLE** is foldaway, and can operate in the extended operation position without requiring removal of the bucket.

Features:

- Hollow link available for hoses through
- Auto saw bar return
- Heavy duty rotator
- Compact design for installation inside dipper arm
- Low oil flow requirement for saw (160 L/min)
- Heavy duty performance but economical in weight



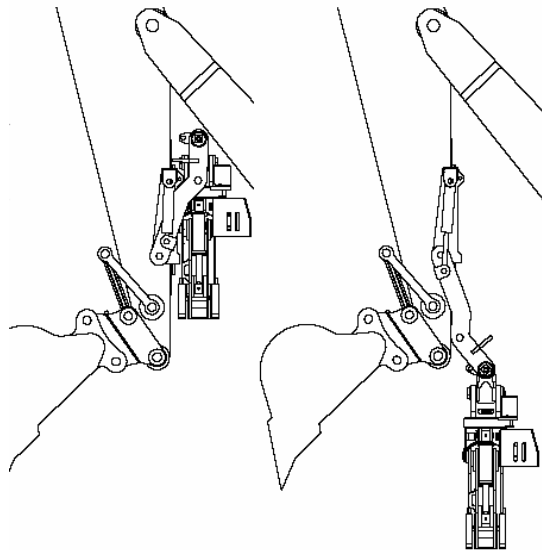
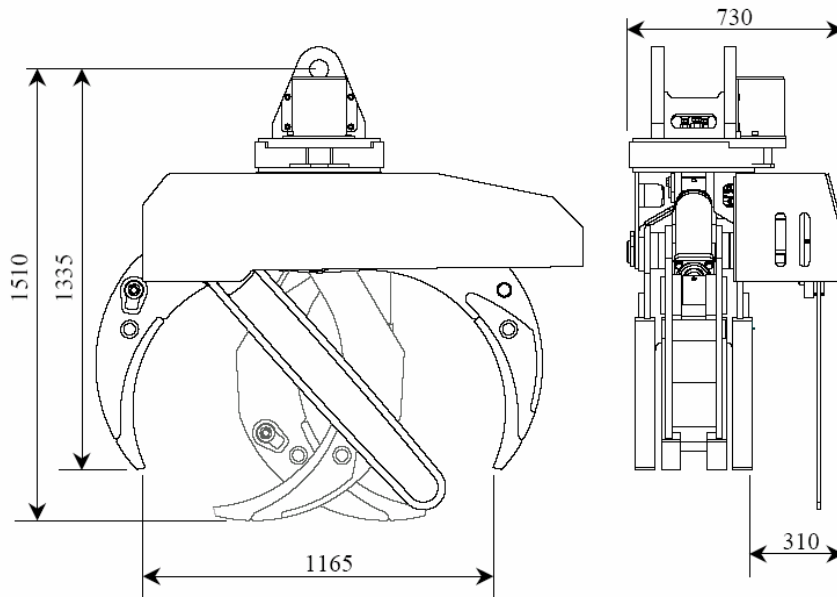

Motor Displacement	30cc
Chain Pitch	3/4in
Cut Diameter	97cm (38in)
Bar Length	41in
Rotation	Continuous
Torque @ Relief pressure	2'420Nm @ 1000bar (21,41n.lb @ 1450 psi)
Grapple/Saw/Pak assy.	1'267kg (2'787lb)
Grapple/Saw	815kg (17'93lb)
Maximum Load	15'600kg (34'320lb)

